



Editor's Photo of the Month

This stunning action image was captured by Neal Schorr during a round trip cab ride that his son Stephen, the conductor of this Reading, Blue Mountain and Northern Railroad locomotive, organized between Reading and Pittston. Neal won Second Place for this photo in our November Bring'n'Brag contest.

**Submission Deadline for next Flyer:
January 22, 2023**

Visit us online at
keystonedivision.org

Get the Color Version of the Keystone Flyer — as well as Online Extras — as soon as it comes out and other Division 2 news flashes and announcements via email. Contact Susan Werner:

swerner48@yahoo.com

Meeting Schedule

January 15, 2023 - Division 2 Meeting, 2:30pm
Marshall Township Municipal Building
525 Pleasant Hill Road, Suite 100
Wexford, PA 15090
Program: Richie Jodon, Airbrushing

February 19, 2023 - Division 2 Meeting, 2:30pm
Weirton Area Museum & Cultural Center
3149 Main Street
Weirton, WV 26062
Program: George Pandelios, Building Weirton Steel

Bring'n'Brag

Jan	Anything goes
Feb	Motive Power: Diesel, Electric & Traction
Mar	Motive Power: Steam
Apr	** Model Railroad Jamboree **
May	Freight Cars
Jun	Non-Revenue (incl. cabooses)
Aug	Passenger Cars
Sep	Vehicles
Oct	Structures
Nov	Prototype Photos



From the Super's Desk

Let me start off by wishing you all the best of the season! I hope you have a great and safe holiday. To me, this is the Most Wonderful Time of the Year and I look forward to sharing it with my family and friends.

For many of us, this is the season that many of us got our first "train set" and started on a journey that continues today. From those humble beginnings, many of you have created some amazing miniature worlds. We've all had fun and learned many things along the way.

Model trains are still closely associated with the season and many of our area model railroad clubs are hosting open houses that are attended by many non-model railroaders. It's a great time for us to fan the sparks that some of those "civilians" catch to see if a true fire of interest develops.

Please take any opportunity to get out a visit these layouts. You'll learn something new at each one and might even light the spark in another visitor.

It's also a great time to share your layout or handiwork with people at work or in your neighborhood for yet another opportunity to light a spark.

I want to take time to express my appreciation to my fellow officers and all the committee heads and members that are serving the division. You are a great asset to our membership and allow our organization to do some great activities and events.

I also want to thank our membership for your continued support of division activities. We've had great attendance at our monthly meetings and a successful Jamboree. We have some big plans for next year as we host the Regional Convention as well as a great line-up for our monthly meetings.

Thank you one and all. Enjoy the season! I look forward to seeing you in 2023.

... *Dennis Coglianese*

LOOKING FOR A FEW GOOD PROGRAMS

Do you have a good topic you'd like to present? Know some tips on how to do something? Want to talk about a field trip you made? Well, the Division is looking for you. The new year beckons, and we have a number of slots for programs following the monthly division business meetings. Your talk doesn't have to be long: 20-30 minutes is just right. That works out to (roughly) 10-15 PowerPoint slides.

The Division has everything you might need – projector, computer, PowerPoint, and even a screen. And if you need help making the presentation, I would be happy to help you. We can get together via Zoom or in person.

George Pandelios, Asst. Superintendent

Division Elected Officers

Superintendent

Dennis Coglianese
(412) 418-9150
DJCoglianese@comcast.net

Asst. Superintendent

George Pandelios
(717) 503-3192
gpandelios@verizon.net

Chief Clerk

Mike DeSensi
(412) 613-4383
chiefclerk.div2@gmail.com

Division Appointed Officers

Treasurer

Jeff Gregg
(724) 348-5855
jwg625@comcast.net

Company Store

Susan Werner
(724) 379-8584
swerner48@yahoo.com

Achievement Program

Dennis Vaccaro
(724) 929-2190
vaccaro_dennis@yahoo.com

Bring'n'Brag

Tracy Boyd
(410) 919-7115
Richard Terek
rjtgbg1@comcast.net

Webmaster & Membership

Tom Gaus
(412) 731-8846
webmaster@keystonedivision.org

Keystone Flyer Editor

Patrick Altdorfer
(412) 559-3079
patrick.altdorfer@gmail.com

Jamboree Committee

Grier Kuehn gekuehn@comcast.net
Neal Schorr naskss@yahoo.com

Module Committees

FreeMo (HO scale) group
Patrick Altdorfer patrick.altdorfer@gmail.com

T-Trak (N scale) group
Richie Jodon richjodon30@gmail.com
Jim Braum jimmy_braum@yahoo.com

The *Keystone Flyer* is published ten times a year by Division Two of the National Model Railroad Association, Mid-Central Region. Subscription to the *Flyer* is included with your NMRA membership and sent via e-mail directly to each member who chooses to receive the newsletter in this format. Alternatively, you may also read the *Flyer* online, or download a copy onto your computer or mobile device by navigating to the link on the Division Two website [www.keystonedivision.org]. Members without internet access or an e-mail address may request a printed copy from the Division; please send your name, address, and phone number to: Patrick Altdorfer, Editor, 6333 Morrowfield Avenue, Pittsburgh, PA 15217. Pike ads are available to publicize your home or club model rail empires for a \$15.00 yearly fee. You may supply artwork or have it produced by the editor for a nominal fee. Pike ads are also posted in full color on the Division website.

November 20, 2022 Business Meeting

After a short delay due to the swap meet, Superintendent Dennis Coglianesi opened the November Division 2 business meeting at 2:52 PM.

He thanked the New Eagle Model Railroad Club for hosting the meeting. New Eagle MRR President Ray Helster thanked everyone for attending.

Pass the Hat: Jeff Gregg passed the hat.

New members and/or guests: We had one new member in attendance: Dave Martinelli is an HO scale modeler focusing on the Bessemer & Lake Erie Railroad.

Frank Benders moved, and Bill seconded, a motion to accept the October meeting minutes as published in the November Keystone Flyer; the motion passed unanimously.

Committee Reports

Keystone Flyer – Patrick Altdorfer. The January Flyer submission deadline is December 11. Patrick noted that, as usual, there is no Flyer for December. He once again solicited feature articles for the Flyer.

Treasurer – Jeff Gregg reported that the division is solvent.

Programs – George Pandelios. George provided the following updates for the next business meetings through May 2023:

- January 15, Marshall Township. Program: Airbrushing by Richie Jodon. Neal Schorr stated that his home layout would be open for viewing, weather permitting. George will have his layout open for viewing.
- February 19, Weirton, WV. Program: Weirton Steel in O Scale by George Pandelios.
- March 19, Morgantown, WV. Program to be determined.
- April 16, Ohio Valley Lines, Ambridge. Program to be determined. George also noted that Ohio Valley Lines will host the Division Business meetings in May, starting in 2024.
- May 4-7, MCR Regional Convention, Cranberry Twp, PA.

Company Store – Susan Werner. Lots of new stuff plus convention pins, patches, and belt buckles; also, re-stock of NMRA Standards Gauges.

Website & Membership – Tom Gaus. Tom noted that the Division membership is currently 199. The website is up-to-date, as is the 2023 Convention page.

Free-Mo – Patrick Altdorfer. The Free-Mo group received confirmation of their participation at the Greenberg Train Show on 7-8 January 2023 show in Monroeville, PA.

Bring & Brag – No committee chair was present. The category was Prototype Photo. After an executive decision by Superinten-

dent Coglianesi, voting took place and the winners were: 1st Place – Terry Stuart, Conway Hump; 2nd Place – Neal Schorr, Reading & Blue Mountain cab view; 3rd Place – East Broad Top #17 at rest.

Video Library – Bud Brock. The video library has been dormant since pre-COVID. Bud asked for the Board of Directors to recommend changes to the library to make it more accessible, motion for changes seconded by Dennis Vaccaro.

Achievement Program – Dennis Vaccaro. Dennis noted that a Merit or AP certificate has been awarded at every meeting this year. Two Merit Awards were presented to Ray Helster for his barn and silo (Bring & Brag winners from the October meeting); see the Keystone Flyer for additional details. A freight car by Susan Werner is being judged after the meeting, please come and view the process.

T-TRAK – Richie Jodon. Richie reported that the Division T-Trak had a good showing at the November Greenberg Show in Monroeville, PA earlier this month. The group is always looking for additional modules for the show. On Saturday, December 3, the group will have the layout on display at the Washington Twp (Fayette County) Christmas event.

Regional Convention – Keith DeVault. Superintendent Coglianesi stated that the committee is meeting once a month and things are moving forward. Clinics are filling up; Modeling with the Masters with Sam Swanson has been confirmed; Bill Neale will be the banquet speaker. Current challenges remain in securing bus transportation for tours. The registration price will go up February 1, 2023. Patrick Altdorfer asked where the Division Free-Mo layout was going to be placed; the layout will be in the common area of the hotel. Dave Kitsch asked about having the Western PA Model Railroad Museum on the tours. This was met with some criticism because of the misconception of animosity between the Division and the WPMRRM.

Old Business

Grier Kuehn asked for a motion to approve the previously discussed Jim Sacco Memorial Award (see last month's Minutes for details) with the stipulation that the award would be presented on an occasional or as-needed basis. Motion to accept forwarded by Susan Werner, second by Jim Kubanick, unanimous vote to approve.

The issue of records retention was brought up again. The retention of anything critical to the history of Division 2 (Flyers, web pages, Jamboree / Convention posters & graphics, etc.) will be the responsibility of the Chief Clerk. Current Clerk Mike DeSensi noted that the generic Chief Clerk email (chiefclerk.div2@gmail.com) comes with 15gb of storage and that will become the main repository of the records retention once it has been organized.

New Business: None

... continued on page 6

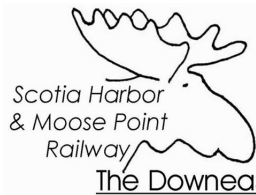

Susan Werner, CEO
292 Salem Church Rd.
Belle Vernon, PA 15012
swerner48@yahoo.com

Cumberland and Lake Erie Railroad



"The Laurel Ridge Route"

D. E. Baker, V.P. of Operations
118 Laurlis Lane, Johnstown, PA 15904 dbakerr@aol.com



HUNTINGDON NORTHERN RAILWAY



"THE ALLEGHENY ROUTE"

R.J. Prehoda, Operations Manager

Serving Southwestern Pennsylvania with connections to:
B&O, CP&W, Erie Lackawanna, N&W, NYC, P&WV, PRR, WM



Turtle Creek Railroad

"The Hardshell Route"

Serving the Center of the Universe

Ken Hanawalt (724) 941-3186
email: TurtleCreekRailroad@verizon.net

Snappy Service

FREEMPORT AND CONEMAUGH The Yellowjacket Line



SALTSBURG AND SLICKVILLE

Serving PA Coal Country

Robert Livrone, Owner/Operator Lower Burrell, PA

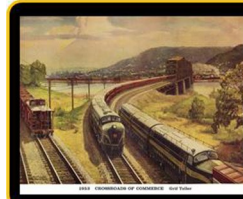

PRR Panhandle Division



George Pandelios Chief Engineer
Member: NMRA, TCA, PRRT&HS
717.503.3192 gpandelios@verizon.net



The ASPEN SUB along the B&O
from Morgantown to Keyser

Keith and Janet DeVault
546 Aspen Street, Morgantown, WV
(304) 276-2509 devaultkj@comcast.net

--- YOUR AD HERE ---

HO/HON3



Blacklog & Shade Gap Eastern Railroad

Vagel Keller, Gen'l. Manager
vckeller@comcast.net

Follow our construction progress online at:
http://www.railroad-line.com/forum/topic.asp?TOPIC_ID=22893

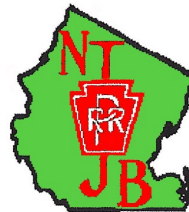

PENNSYLVANIA RAILROAD NORTH JERSEY BRANCH

John W. Wesner
Owner & Chief Engineer
3844 Henley Dr., Pittsburgh, PA 15235
412-731-7393 wesnerj@asme.org



PENNSYLVANIA RAILROAD MIDDLE DIVISION

Hey kids, you too can be a fan of the
great Standard Railroad of the World!

Neal A. Schorr - Owner & Chief Engineer



LEBANON VALLEY RR

Serving Pittsburgh Suburbia and Beyond
Phineas T. Foonman, Emperor and CEO

Jim Ferguson (412) 561-5203
email: drfergie44@gmail.com



BALTIMORE & OHIO WESTERN MARYLAND Consolidated Rail System



with connections to P&E, PRR, C&O, EL, NYC

Chief Engineer John Bennett
Phone: (814) 241-5547
Johnstown, PA



Rutland & Rock Ridge

232 Old Farm Road
Cranberry Township, PA 16066
Haulin' Black Diamonds

Fred Roney, President
fredron@zoominternet.net



FORKS RIDGE RAILWAY



Gary P. Nastase - President & CEO
Kathleen A. Nastase - Train Wifey ... R.I.P.
207 State Street
Woodbury, PA 16695
gnastaseo2jzo@gmail.com

Route of the
Whitetail

THE O.R.N. Ry BUNCH

15
LAYOUTS
AND
GROWING
N-HO-O-G



CONTACT
JOEL EVERLY
(740) 282-9854
NEW MEMBERS
WELCOME

OHIO RIVER NORTHERN RAILWAY CLUB

Bring'n'Brag

Tracy Boyd/Richard Terek

November 2022

This month's category was Prototype Photographs. We had three entries photos submitted by three members, and the voting resulted in the following outcomes for the month:

First place went to Terry Stuart, who entered two photos he took in the early 1960s of the Johnstown Yard (left) and the hump at Conway Yard (below).



Second place went to Neal Schorr, who caught a cab view "action shot" (featured on the cover this month) at night on an RBMN locomotive conducted by his son Stephen. Interestingly, Neal achieved this effect using only a smart phone camera set to a long exposure.

Third place went to Jimmy Braum, who entitled his photo (at left) "East Broad Top #17 at rest." He took this photo this summer and then "aged" it using photo editing software to present an image that looks as if it could have been taken in the early 20th century.

With that, we wrap up the 2022 Bring'n'Brag contests, and the table below presents the final standings for the year. Thank you to everyone who participated in the contests this year !



The January contest category is **Anything Goes**. Bring your entry to the meeting **no later than 2pm on Sunday, January 15** in order for your entry to be considered in the contest.

Name	pts	Name	pts
Jimmy Braum	11	Jim Hofer	4
Joel Everly	9	W. Terry Stuart	3
Rick Montgomery	7	George Pandelios	2
Neal Schorr	7	Mark Vinsky	1
Ray Helster	5	Bob DiBenedetto	1



WHAT'S ON YOUR WORBENCH ?

Dennis Coglianese started his tenure as Superintendent last year asking us the above question at the close of our meetings, and there have been quite a few interesting updates volunteered by members about the modeling projects they have just completed, are working on, or are planning for the near future. One of these is featured here, which Ken Hanawalt described at the November meeting and which is also available on the Division Two website [here](http://www.keystonedivision.org/report_folder/wheelchock.html) (www.keystonedivision.org/report_folder/wheelchock.html). Hopefully this will be the first of many contributions by members highlighting their modeling projects.

Print your own Wheel Chocks

by Ken Hanawalt

Tom Frommeyer and I are using our own 3-D printed wheel chocks on the Turtle Creek Railroad to keep cars from rolling off the end of the track on a car barge. The wheel chock model is based on a prototype photo located on the "Model Train Geek" website [here](http://modeltraingeek.com/wp-content/uploads/2015/12/Track-Bumper-Corner-Brook-20151028-SLB-2.jpg) (modeltraingeek.com/wp-content/uploads/2015/12/Track-Bumper-Corner-Brook-20151028-SLB-2.jpg). The wheel chock fits snugly over code 100 rail and will hold a car from rolling. On the layout it could be secured if needed with a dab of glue (such as plastic model cement or cyanoacrylate).



Prototype photo of the wheel chock Ken and Tom used as the basis for their design of the model; photo by Steve Boyko, blogging at "traingeek.ca".



This photo shows the wheel chock models installed on the barge.

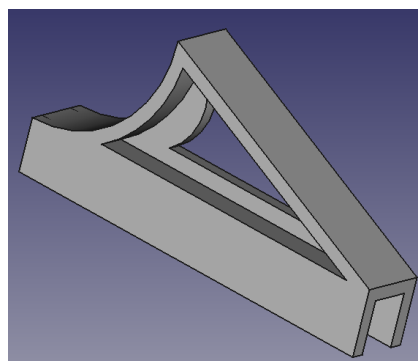

This image ("WheelChockClip.png" shows the design created by Ken and Tom, as displayed by the FreeCad design tool (more info on this at freecadweb.org).

The file "WheelChockD-Body.stl" is a Stereo Lithographic file that you can use with a slicer to make prints of the design on a 3-D printer. Download the file from the Keystone Division website [here](http://www.keystonedivision.org) (or navigate on the home page to the section entitled "Clinics, Presentations and Videos").

Minutes

... cont'd from page 3

For the Good of the Division:

Ken Hanawalt and Jimmy Braum both stated that their respective home layouts will be open for visiting after the meeting.

Andy Blenko has extra PRR style signals from his layout available to whoever wants one.

Fred Abrew brought a diverse collection of O scale items; all items are free for the taking.

Susan Werner mentioned the New Eagle VFD Train show will be January 24, 2023, from 10AM – 4PM.

George Pandelios requested submissions for presenters for March and beyond for the meetings. He also mentioned that he has start-

ed working at Hobby Express in Cranberry and the shop has expanded again. Hours for Hobby Express, 1713 PA-228, Cranberry Twp, PA 16066 are 10AM – 7PM Monday-Saturday and 10AM – 5PM Sunday.

There being no further business, Superintendent Coglianese asked for a motion to adjourn the meeting; motion by Dennis Vaccaro, seconded by Mike DeSensi. Time of adjournment not noted (Apologies, MGD).



REMINDER: RENEW YOUR PIKE AD !

A new year begins, and that means it is again time to renew your pike ad! \$15 gets 10 insertions in the Flyer and presence on the Division website. Please send your check made out to Division Two, NMRA, MCR, and send to P.O. Box 223, Gastonville, PA 15336. Thank you!

MEETING TIMETABLE

January 15: Wexford, PA

Our January meeting will be held at the Marshall Township Municipal Building (525 Pleasant Hill Road, Suite 100, Wexford, PA 15090), which Neal has coordinated for us again this month. Afterward Richie Jodon will present this month's program on "Airbrush Painting." Two O-scale layouts will be open for members to visit: George Pandelios will open his layout, the PRR Panhandle Division, before the meeting from 11am to 1pm, and again after the meeting from 4-6pm (**420 Wealdstone Road, Cranberry Twp., PA 16066**; plenty of parking in front of the house on either side of the island divider). And if Mother Nature cooperates by providing mild weather, Neal Schorr will also open his layout, the PRR Middle Division, before the meeting from 11:30am-1:00pm (**115 Hilltop Lane, Wexford, PA 15090**); **he will NOT be open if there is snow or ice** due to his somewhat treacherous driveway).

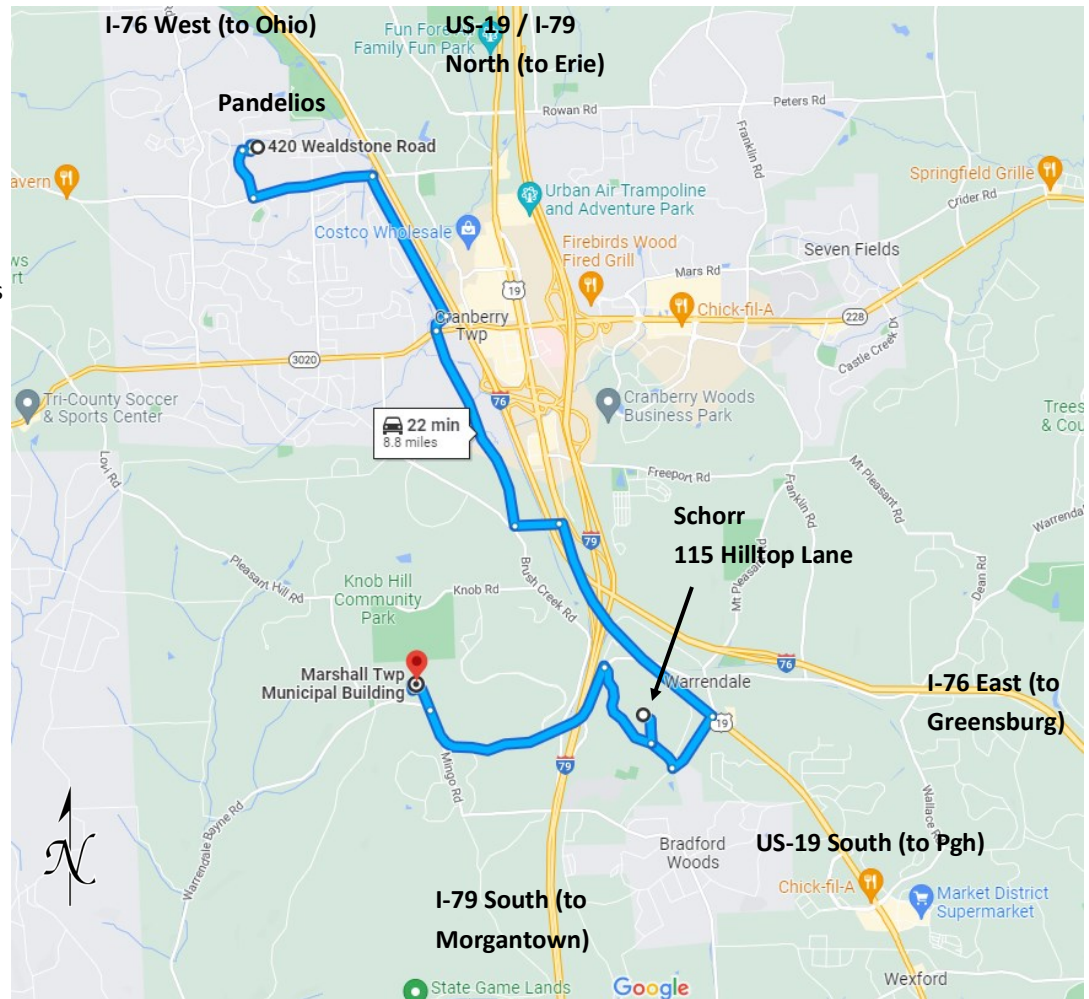

February 19: Weirton, WV

Our February meeting will be held at the Weirton Area Museum and Cultural Center (3149 Main Street, Weirton, WV 26062). After the meeting, George Pandelios will present a program on "Building Weirton Steel." The museum will open for us at 12 noon and will close after we are done; as of editorial deadline, open houses at local layouts have not been reported.

The Keystone Flyer
 Division Two, NMRA, MCR
 P.O. Box 223
 Gastonville, PA 15336



NEXT MEETING:
January 15, 2023, Marshall Twp. Municipal Bldg, Wexford, PA

 <p>Mon Valley Railroad Historical Society 128 Pleasant Street Morgantown, WV 26505</p> <p>Meeting Thursdays at 7:00 PM www.MVRRC.org Call Rich Henderson (304) 276-1046 for more info</p>	 <p>MID-MON VALLEY MODEL RAILROAD CLUB</p> <p>159 Main Street, New Eagle, PA Meetings: Fridays 7:30 pm</p>
 <p>Visitors Welcome MEMBERSHIP OPEN</p> <p>2209 Walnut Street McKeesport, PA</p> <p>Open Wednesday & Friday Evenings</p>	 <ul style="list-style-type: none"> • HO & N Scale Layouts • T-TRAK Modular Display Layout • Extensive Library & Video Collection <p>OHIO VALLEY LINES 1225 MERCHANT ST AMBRIDGE PA 15003</p> <p>www.ohiovalleylines.org info@ohiovalleylines.org Open Every Monday 7:30PM – 10:00PM Memberships available!!</p>
<p>All aspects of "S":</p> <ul style="list-style-type: none"> • Scale • Narrow Gauge • Hirail • American Flyer <p>Monthly meetings Two portable layouts Membership open Contact: Jon Knox 724-287-6829</p> 	 <p>BEAVER COUNTY MODEL RAILROAD and HISTORICAL SOCIETY</p> <p>416 6th St. Monaca, PA 15061</p>  <p>Visitors Welcome</p> <p>Worknights: Tuesdays 7:30 www.bcmrr.railfan.net</p>

Division 2 Needs You !



I WANT YOU

Unlike Uncle Sam, who required a 6 year obligation, the Division only needs you for a handful of hours over the course of 3 days at the Rails to Pittsburgh MCR Convention in May! Help us make this convention a huge success by lending a hand. We plan to have enough volunteers to share duties so no one will miss out on a clinic or other activity they want to attend. Besides the satisfaction of being part of this great event, you will earn "volunteer" hours toward your NMRA Association Volunteer Certificate. Please email me at: volunteer@RailsToPittsburgh.com for more details.

- Grier Kuehn